

# Medium Bi-Pin Lampholders

Specially designed for electronic ballasts



NRTL/C

## 1550 Series Turn-Type Lampholders

### Specifications

**Rating:** 660 Watts, 600 V

**Listing:** UL File No. E-13408; CSA File No. LR95423

**Mounting:** Slide-on for 18 or 20 gauge panels;  
optional self retaining mounting nut;  
6/32 x 1/2" screws available in bulk;  
or spring clip.

### Materials

**Housing:** White urea

**Contacts:** Copper alloy, surface wipe configuration

**Termination:** "Wire fast" terminals for No. 18 AWG stranded (twisted, tinned and solder dipped or fused) or No. 18 AWG solid copper wire with 3/8" strip length.

**Special:** Item can be factory wired per customer specifications for length, strip and wire material.

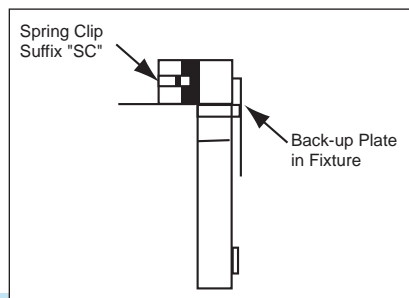
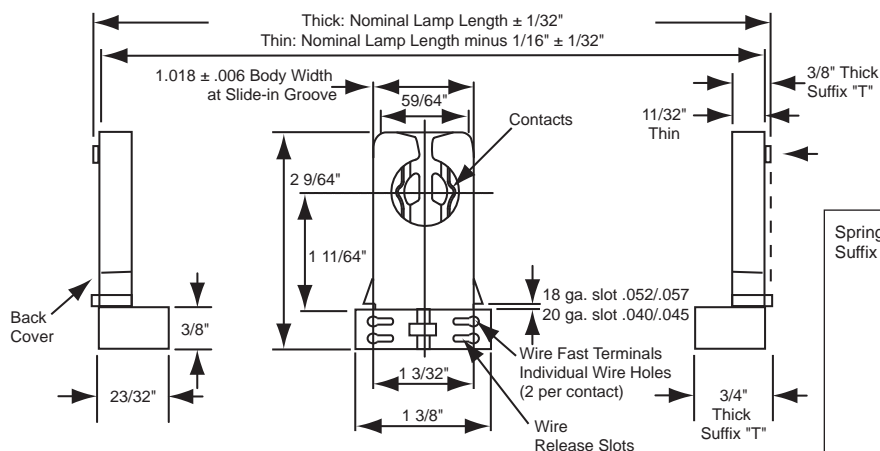
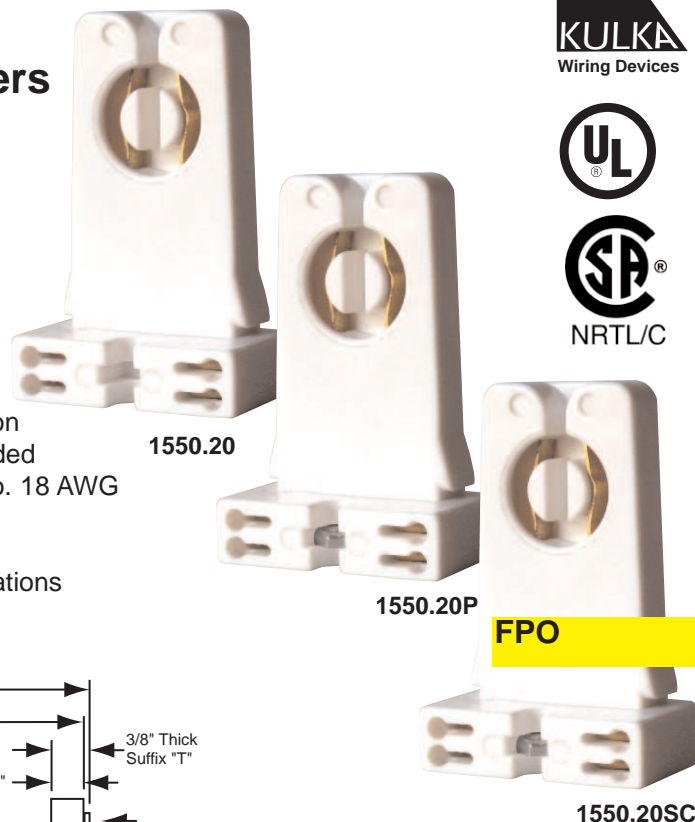

## Kulka® 1550 Series

Part No. 18 gauge	Part No. 20 gauge	
1550.18	1550.20	With 11/32" body thickness
1550.18P	1550.20P	With pre-assembled No. 6-32 palnut
1550.18SC	1550.20SC	With pre-assembled spring clip
1550.18D	1550.20D	With circuit interrupting disconnect
1550.18T	1550.20T	With 3/8" body thickness
1550.18SCD	1550.20SCD	With pre-assembled spring clip and circuit interrupting disconnect
1550.18SCT	1550.20SCT	With pre-assembled spring clip and 3/8" body thickness
1550.18SCDT	1550.20SCDT	With pre-assembled spring clip, circuit interrupting disconnect & 3/8" body thickness
1550.18PD	1550.20PD	With pre-assembled No. 6-32 palnut and circuit interrupting disconnect
1550.18PT	1550.20PT	With pre-assembled No. 6-32 palnut and 3/8" body thickness
1550.18PDT	1550.20PDT	With pre-assembled No. 6-32 palnut, circuit interrupting disconnect and 3/8" body thickness

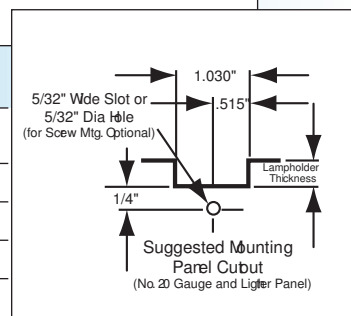

Packed 1000/ box. No. 6/32 x 1/2" screws supplied in bulk (p/n: 8063.216.001)